



SOCIETA' COOPERATIVA
BILANCI
Weighing Instruments and Technology



D70E

WEIGHING INDICATOR
WITH TCP/IP ETHERNET PORT

D70E

WEIGHING INDICATOR
WITH TCP/IP ETHERNET PORT



Declaration
of Conformity



CE metrology approval
(Directive 2014/31/EU)



Certification
OIML R76-1



WEIGHING INDICATOR WITH TCP/IP PORT

D70E is a weighing indicator for general purpose applications **equipped with Ethernet TCP/IP communication port.**

It has a LED display and a membrane keyboard and features an extraordinary value for money.

It is particularly suitable for small and medium weighing where a highly readable display is required; available in versions with:

- **AA batteries**
- **Rechargeable internal Lithium battery**
- **12-24Vdc extended power supply, 0-10Vdc / 4-20mA analogue output, 2 digital INPUTS and 2 digital OUTPUTS**

With **CE approval** in accordance with Directive 2014/31/EU, it can be connected to any type of analogue load cell in Single or Multi-range version.

STRENGTHS

- **BUILT-IN ETHERNET TCP/IP COMMUNICATION PORT**
- **POSSIBLE OPERATION AS WEIGHT “REPEATER”**
- **EASILY PANEL-MOUNTED COMPACT DESIGN**
- **NATIVE MODBUS TCP/IP PROTOCOL FOR CONNECTION WITH PLC**
- **VERSION WITH INTERNAL RECHARGEABLE BATTERY**
- **VERSION WITH DIGITAL I/OS AND ANALOGUE 4-20mA / 0-10Vdc output**

TECHNICAL SPECS.

COMMUNICATION PORTS	X1 Ethernet TCP/IP X1 RS232/RS485		
NUMBER OF LOAD CELLS	4x350 Ω		
LOAD CELL POWER SUPPLY	5Vdc		
MAX RESOLUTION FOR "LEGAL USE"	6000 div. OIML (max 3 ranges from 4000 divisions)		
MAX RESOLUTION FOR "INDOOR USE"	30000 div.		
OPERATING TEMPERATURE	-10 °C / +40 °C		
STORAGE TEMPERATURE	-20 °C / +70 °C		
RH % (max non-condensing relative humidity)	85%		
PANEL PROTECTION RATING	IP65		
DISPLAY	7-segment red LEDs h 20 mm		
VERSION	STANDARD	WITH RECHARGEABLE BATTERY	WITH ANALOGUE OUTPUT AND I/OS
POWER SUPPLY	12 Vdc / 110÷240 Vac 6 x 1.2 V AA, rechargeable 6 x 1.5 V AA, alkaline	12 Vdc / 110÷240 Vac Rechargeable internal lithium battery	12-24 Vdc on terminal board
RUNNING TIME	16h (single-cell)	16h (single-cell)	
ANALOGUE OUTPUT			0-10V 4-20mA
DIGITAL INPUTS			X2 Requires a dry contact
DIGITAL OUTPUTS			X2 Vmax 24Vac/Vdc Imax 190mA



FUNCTIONAL SPECS.

OPERATING MODES:

- Simple weighing
- Piece counting
- Subtotal and general total by weight and pieces with weighing reports
- Setpoint management (I/O version)
- Simple Loading / Unloading Extraction (I/O version)
- Extraction with slow and overhead weight management (I/O version)

FUNCTIONS:

- Weight repeater
- Printer management
- Date and time management
- Automatic or preset tare
- MPP legal weighing management (optional)

COMMUNICATION PROTOCOLS AVAILABLE:

- MODBUS RTU
- MODBUS TCP/IP
- Cyclical or on-demand sending of weight
- Sending of weight upon key pressing
- Remote controls



PRINTOUT EXAMPLES:

Data	03/10/2013
Ora	11.04.28
N.Pesate	1
Tara	250 kg
Netto	19720 kg
PEZZI	197

Pesatura Bilanciai Group

Data	03/10/2013
Ora	11.04.52
N.Pesate	2
Tara	50 kg
Netto	14921 kg
PEZZI	149

Pesatura Bilanciai Group

Printout with piece counting function

Data	03/10/2013				
Ora	11.04.56				
Data	Ora	Netto	Tara	PEZZI	
1	031013	110428	19720	250 kg	197
2	031013	110452	14921	50 kg	149

Summary printout
(Available only with STB2080)

Totale Parziale	
Data	03/10/2013
Ora	11.04.59
N.Pesate	2
Tara	300 kg
PESO	34641 kg
PEZZI	346

Totale Generale	
Data	03/10/2013
Ora	11.05.03
N.Pesate	2
Tara	300 kg
PESO	34641 kg
PEZZI	346

General total printout

ACCESSORIES

- Panel mounting support
- Battery kit
- Kit for wall-mounting
- Column kit for mounting on **PMA**
- "Compact" configuration kit to be mounted at the bottom of **PMA**
- Stand kit
- MPP for legal weighing saving
- Available Tool SW on PC for connection to the indicator



D70E on platform-mounted column mod. **PMA**



D70E connected to platform mod. **PMA** with "compact" configuration

CONNECTABLE PRINTERS



STB2080

Size: 209 (L) × 140 (W) × 152 (H) mm



LP55

Size: 197 (L) × 120 (W) × 102 (H) mm

DESKTOP VERSION

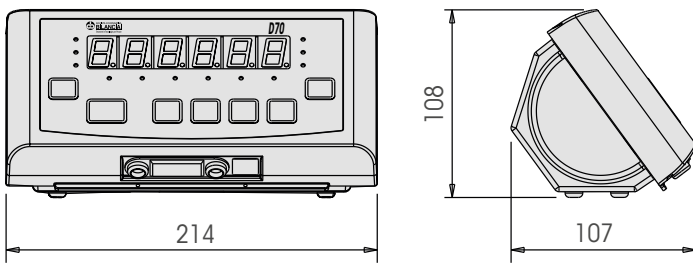

WALL MOUNTED VERSION

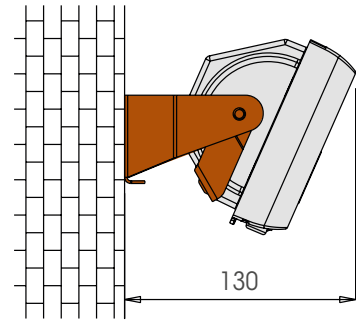

PANEL MOUNT VERSION

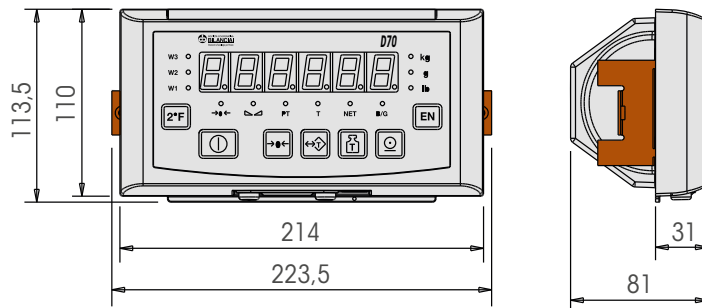

Panel slot for rack version
(dimensions 200x104)

COMPACT
CONFIGURATION
ON PMA

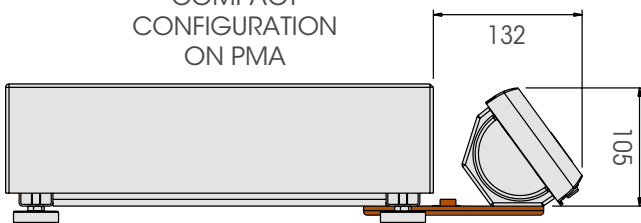

COLUMN WITH PEDESTAL
FOR CONNECTION
TO PLATFORM SCALE

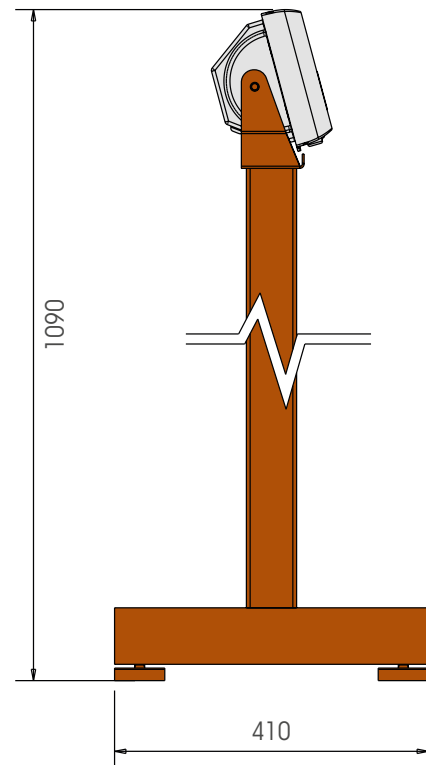

COLUMN
FOR APPLICATION
ON PMA

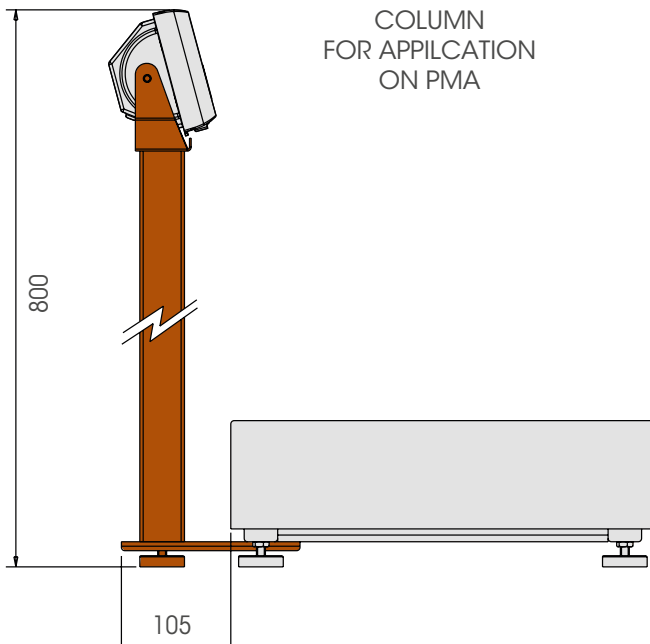

 = Accessories



Società Cooperativa Bilanciai Campogalliano
41011 Campogalliano (MO) Italy
Via S. Ferrari, 16 - Tel. +39 059 893611
Customer Service - Tel. +39 059 893612
www.coopbilanciai.it - info@coopbilanciai.it



In order to technologically improve its production, the company reserves the right to make changes and modifications to the products shown in the above pictures at any time and without prior notice.
02/2023 Edition